

Specification for Li-ion Rechargeable cylindrical battery

圆柱锂离子电池 规格书

MODEL/型号:

INR18650-3000

Prepared By 编制	Checked By 审核	Approved By 批准	Effective date 生效日期
Jia Chen 陈佳	Zhi Hong Wu 吴支红	Robin Song 宋泽斌	2023/07/21

Customer Approval 客户承认	Signature 签字	Date 日期
	Company Name: 公司名称:	
Company Stamp: 客户印章:		

1.0 Scope 适用范围

This document describes the Product Specification of the Lithium-ion rechargeable battery cell supplied by Jiangsu SunPower CO., Ltd.

本规格说明书描述了长虹三杰新能源有限公司的可充电锂离子电芯的产品性能指标。

2.0 Specifications 基本规格

NO	Items 项目	Specifications 规格
1	Model 型号	INR18650-3000
2	Nominal capacity 标称容量	3000mAh Charge: 1500mA, 4.20V, CCCV 60mA cut-off, Discharge: 600mA, 2.50V discharge cut-off
3	Min Capacity 最小容量	2900mAh Charge: 1500mA, 4.20V, CCCV 60mA cut-off, Discharge: 600mA, 2.50V discharge cut-off
4	Nominal Voltage 额定电压	3.70V
5	Max. Charge Voltage 最大充电电压	4.20V ± 0.05V
6	Standard Discharge Cut-off Voltage 标准放电截止电压	2.50V
7	Standard Charging Mode 标准充电模式	CC-CV (cut-off current is 60mA) 恒流恒压 (恒压截止电流为 60mA)
8	Standard Charge Current 标准充电电流	1.5A
9	Max. Charge Current 最大充电电流	3A
10	Charge Time 充电时间	180 分钟 (25 ± 3°C) 180min (25 ± 3°C)
11	Max. Continuous Discharge Current 最大持续放电电流	10A

12	Max. Pulse Discharge Current 最大瞬间放电电流	30A (2s pulse)	
13	Standard Diameter of battery (include PET) 电池标准直径 (包含PET 外壳)	≤ 18.50 mm	
14	Standard Height of battery (include PET) 电池标准高度 (包含 PET 外壳)	≤ 65.30 mm	
15	Weight 电池重量	≤ 49.0 g	
16	AC Impedance (at 1000Hz、30%SOC) 交流内阻 (at 1000Hz、30%SOC)	≤ 20 m Ω	
17	Pack consistency 配组一致性 (内控标准)	Δ Voltage 电压差	≤ 10 mV
		Δ Impedance 内阻差	≤ 2 m Ω
		Δ Capacity 容量差	$\leq 1\%$ 标称容量
18	Status of the cell as of ex-factory 出厂电压	3.500V~3.650V	
19	Operating temperature (surface temperature) 使用时电芯表面温度	Charge 充电	0°C~45°C
		Discharge 放电	-40°C~75°C
20	Storage temperature 储存温度	3 months 3 个月	-20°C~45°C
		1 year 1 年	-20°C~25°C

Note:

If the cell is kept as ex-factory status (30% of charge), the capacity recovery rate is more than 90% of standard discharge capacity.

如果存储时电芯为出厂状态 (约 30%的充电容量)，这种情况下，恢复的容量 \geq 标准放电容量的 90%。

3.0 Configuration 外形示意图

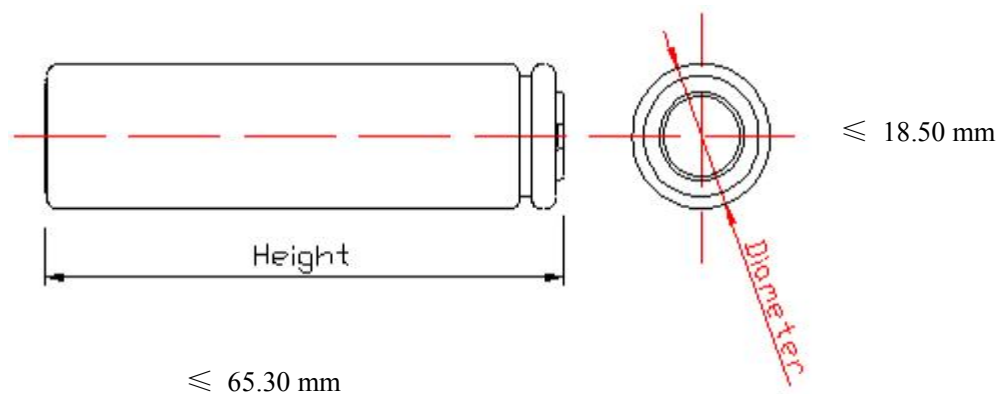

4.0 Characteristic 电池性能

a. Environmental conditions 测试环境

Unless otherwise specified, all tests stated in this specification are conducted at temperature $25^{\circ}\text{C}\pm 3^{\circ}\text{C}$ and humidity under 65%.

若没有特别说明，电池均在环境温度 $25^{\circ}\text{C}\pm 3^{\circ}\text{C}$ ，相对湿度小于 65%的条件下进行测试。

b. Measuring equipment 测试设备

(1) Amp-meter and volt-meter 电流电压测试

The amp-meter and volt-meter should have an accuracy of the grade 0.5mA / mV or higher.

电流电压测试设备的精度需达到 0.5mA/mV 以上。

(2) Slide caliper 尺寸测试

The slide caliper should have 0.01 mm scale. 测量尺寸时游标卡尺需达到 0.01 mm 以上精度。

(3) Impedance meter 内阻测试

The impedance meter with AC 1kHz should be used. 内阻测试在 AC 1kHz 的条件下进行。

c. Standard charge 标准充电

Charging the cell CCCV with charge current 0.5C (1.5A) , constant voltage 4.20V and 60mA cut-off in CV mode at $25^{\circ}\text{C}\pm 3^{\circ}\text{C}$ for capacity.

在 $25^{\circ}\text{C}\pm 3^{\circ}\text{C}$ 环境温度下，充电电流为 0.5C (1.5A)，当电池端电压达到 4.20V 时，改为恒压充电，充电电流小于 60mA 时停止充电。

d. Standard discharge capacity 标准放电容量

Discharge current of 600mA (0.2C) with 2.50V cut-off at $25^{\circ}\text{C}\pm 3^{\circ}\text{C}$ within 1hour after the standard charge.

标准充电搁置 1h 后，在 $25^{\circ}\text{C}\pm 3^{\circ}\text{C}$ 环境温度下，以 600mA (0.2C) 电流放电至 2.50V 的容量。

4.1 Electrical Characteristic 电化学性能

序号 NO.	项目 Item	标准 Standard	测试方法 Test Method
1	Discharge rate capabilities (25°C±3°C) 放电倍率性能 (25°C±3°C)	0.6A ≥ 2900mAh 1.5A ≥ 2850mAh 3.0A ≥ 2800mAh 9.0A ≥ 2750mAh 15A ≥ 2700mAh	Standard charged under the condition of normal atmospheric pressure and the environmental temperature of 25°C±3°C and under 65%RH, then rest for 30mins and discharge at 0.6A、1.5A、3.0A、9.0A、15A to the discharge cut-off voltage respectively (2.5V) . Charge/discharge cycle can be conducted for 3 times before meeting the Standards (the same below) 在 1 标准大气压, 环境温度 25°C±3°C, 相对湿度小于 65% 的条件下, 电池标准充电后 (以下若没有特别说明, 均在此条件下置, 皆按此充电方式), 搁置 30mins, 分别以 0.6A、1.5A、3.0A、9.0A、15A 进行放电至终止电压(2.5V), 循环三次, 当有一次达到标准, 即达到标准要求 (下同)
2	capacity retention and recovery (25°C±3°C) 容量保持及恢复能力 (25°C±3°C)	Residual capacity ≥ 93% Recoverable capacity ≥ 97% 剩余容量 ≥ 93% 恢复容量 ≥ 97%	Standard charged under the condition of normal atmospheric pressure and the environmental temperature of 25°C±3°C, Stored for 30 days, then discharge at 0.2C to 2.50V measuring residual capacity; Then standard charge/discharge measure recoverable capacity. 测量电池的初始状态和初始容量, 电池标准充电后, 在环境温度 25°C±3°C 下开路放置 30 天, 0.2C 放电至 2.50V, 测量电池的剩余容量; 然后标准充放电测试电池的恢复容量。
3-1	Low Temperature Performance (-20°C) 低温性能 (-20°C)	discharge capacity ≥ 80% rated capacity 放电容量 ≥ 80% 额定容量	The cell shall be charged in accordance with the standard charge. Then stored in the temperature of -20°C±1°C for 4h, Discharge at the constant current of 0.2C down to the end-of-discharge voltage 2.50V. 按标准充电方法充电后, 放入 -20°C ± 1°C 低温箱中恒温 4h, 在此条件下 0.2C 放电至 2.50V。

<p>3-2</p>	<p>Low Temperature Performance (-30°C) 低温性能 (-30°C)</p>	<p>discharge capacity ≥70% rated capacity 放电容量 ≥70% 额定容量</p>	<p>The cell shall be charged in accordance with the standard charge. Then stored in the temperature of -30°C±1°C for 4h, Discharge at the constant current of 0.2C down to the end-of-discharge voltage 2.50V. 按标准充电方法充电后，放入-30°C±1°C低温箱中恒温4h，在此条件下 0.2C 放电至 2.50V。</p>
<p>3-3</p>	<p>Low Temperature Performance (-40°C) 低温性能 (-40°C)</p>	<p>discharge capacity ≥60% rated capacity 放电容量 ≥60% 额定容量</p>	<p>The cell shall be charged in accordance with the standard charge. Then stored in the temperature of -40°C±1°C for 4h, Discharge at the constant current of 0.2C down to the end-of-discharge voltage 2.50V. 按标准充电方法充电后，放入-40°C±1°C低温箱中恒温4h，在此条件下 0.2C 放电至 2.50V。</p>
<p>4</p>	<p>Cycle Life (25°C±3°C) 循环寿命 (25°C±3°C)</p>	<p>1.5A charge/ 1.5A discharge ≥500 cycles 1.5A 充电/ 1.5A 放电 ≥500 cycles</p>	<p>Charge: 1.5A charged the cell to 4.20V, then change to charge with constant voltage till the current less than or equal to 0.02C, rest for 10mins; Discharge: 1.5A discharge to 2.50V, one cycle is finished, rest for 30mins. Repeat the above steps, when the capacity retention rate is less than 60%, the test is over. 充电: 1.5A 恒流充电至 4.20V, 然后恒压至电流减小到 0.02C 截止充电, 搁置 10min。 放电: 1.5A 放电到 2.50V, 完成一个循环, 搁置 30mins。 重复上述步骤, 当容量保持率小于 60%, 测试结束。</p>

4.2 Safety Characteristic 安全性能

NO. 序号	Item 项目	Standard 标准	Test Method 测试方法
1	Overcharge 过充性能	No fire、No explosion 不起火、不爆炸	After standard charge, rest for 10mins; then charge at constant current of 3C to 10V.(or charge at 3C for 90mins). 按标准充电后, 搁置 10mins; 3C 恒流充电至电压 10V。(或 3C 充电 90mins)
2	Forced discharge 强制放电	No fire、No explosion 不起火、不爆炸	The battery to be discharged with standard discharging condition, Inverse charge current =1C; time: ≥ 90 mins 按标准放电要求对电池放电, 以 1C 反向充电, 充电时间不低于 90mins。
3	Short Circuit test 短路性能	No fire No explosion 不起火、不爆炸	Standard charged, and short the positive and negative terminals with wire, and the resistance of $80 \pm 20m\Omega$. Tests are to be conducted at $20^{\circ}C \pm 5^{\circ}C$ and $55^{\circ}C \pm 5^{\circ}C$ respectively, The battery is to discharge until a fire or explosion is obtained, or until it has reached a completely discharged state of less than 0.2V and the battery case temperature has returned to $\pm 10^{\circ}C$ of ambient temperature. 标准充电后, 分别置于 $20^{\circ}C \pm 5^{\circ}C$ 和 $55^{\circ}C \pm 5^{\circ}C$ 环境下, 正负极端 $80 \pm 20m\Omega$ 电阻短接。电池保持测试直到爆炸起火或样品达到完全放电状态(电池电压低于 0.2V)或样品表面温度降低至测试温度 $\pm 10^{\circ}C$ 。
4	Crush test 挤压测试	No fire、No explosion 不起火、不爆炸	Standard charged, and crushed between two flat surfaces, the applied force is $13 kN \pm 1kN$ by hydrocylinder, once the maximum pressure has been obtained then release pressure. 标准充电后, 在两个平面间承受挤压, 由液压油缸施加 $13 kN \pm 1kN$ 的挤压力, 一旦挤压力达到卸压。

5	Heating test (130°C) 热滥用测试	No fire、No explosion 不起火、不爆炸	Standard charged, and put into incubator with nature air or circulating air convection, heat by velocity of 5°C ±2°C per minute to 130°C±2°C, and maintain for 30 minutes. 标准充电后，放于自然或循环空气对流的恒温箱中，温度以 5°C±2°C 每分钟的速率升至 130°C±2°C 并保持 30 分钟。
---	----------------------------------	---------------------------------	--

4.3 Environment Adaptation Performance 环境适应性能

NO. 序号	Item 项目	Standard 标准	Test Method 测试方法
1	Altitude/Low pressure simulation test 高空低压模拟测试	No leakage, No fire, No explosion 不泄漏，不起火、不爆炸	Standard charged and stored for 6 hours in an vacuum environment with pressure of less than 11.6kPa and temperature of 20°C±5°C. 标准充电后，储存在 20°C±5°C、大气压≤11.6 kPa 的真空环境中储存 6 小时。
2	Free drop test 自由跌落测试	No fire, No explosion 不起火，不爆炸	The fully charged battery drops on the concrete ground from height (1m), total 3 times, to obtain the shock of random directions. 充满电的电池三次从 1m 高的地方跌落到混凝土地面，以此获得随机方向的冲击。

3	Vibration test 振动测试	No leakage, No fire, No explosion 不泄漏, 不起火、不爆炸	Standard charged and fixed on the vibration table and subjected to vibration cycling that the frequency is to be varied at the rate of 1Hz per minute between 10Hz and 55Hz, battery is to be subjected to simple harmonic motion with an amplitude of 0.8 mm (0.03 in) [1.6mm (0.06 in) total maximum excursion]The cells shall be vibrated for 90 -100minutes per axis of X, Y axes. 标准充电后固定在振动台上, 以振幅 0.8mm,总位移 1.6mm 的单谐振动, 振动频率范围为 10Hz~55Hz, 频率变化速率 1Hz/min。沿 X、Y 两个个方向振动, 每个方向振动 90-100 分钟。
4	Temperature Cycling Test 温度循环测试	No leakage, No fire, No explosion 不泄漏, 不起火、不爆炸	Standard charged, and placed in a test chamber and subjected to the following cycles: a) Raising the temperature to 75°C ±2°C within 30 minutes and maintaining this temperature for 6 hours; b) Reducing the temperature to minus -40°C ±2°C within 30 minutes and maintaining this temperature for 6 hours; c) Repeating the sequences for 10 times, and storing the cells for 24 hours in the condition of temperature 20°C ±5°C . 标准充电后放置在测试箱内并做如下处理: a) 75°C±2°C 搁置 6 小时; b) -40°C±2°C 搁置 6 小时, 温度转换最大间隔时间为 30 分钟; c) 循环 10 次后将电池在 20°C±5°C 下搁置 24 小时。

5.0 Package 包装

The cells are packed with JIANGSU SUNPOWER CO.,LTD. standard carton box, which hold four inner boxes. There are 100pcs 18650 cells per inner box.

电芯使用长虹三杰新能源有限公司标准的包装方式, 每箱有 4 盒,每盒 100pcs.

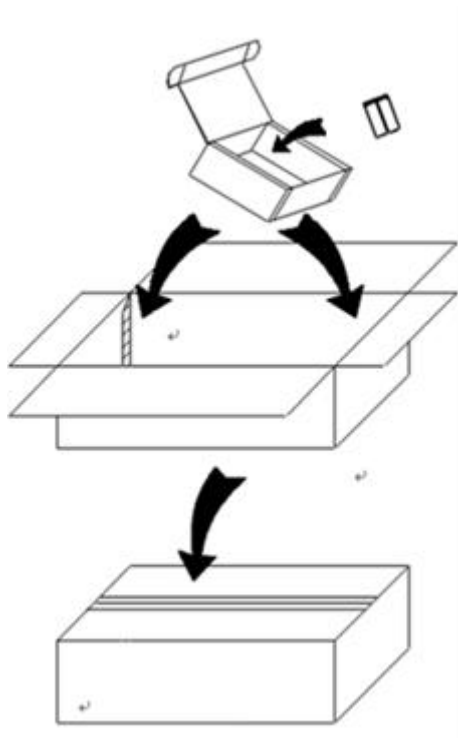

6.0 Warranty Period & Product Liability 保质期及产品责任

Warranty period of this product is 12 months from manufacturing code. JIANGSU SUNPOWER CO., LTD. is not responsible for the troubles caused by mishandling of the battery which is against the instructions in this specification.

保质期是从出厂日期（喷码）开始起 **12 个月**；长虹三杰新能源有限公司对因没有按本规格书规定操作而导致的意外不负责任。

7.0 Warnings and Cautions in Using the Battery 电池使用警告及注意事项

To prevent a possibility of the battery from leaking, heating or explosion please observe the following precautions:

为防止电池可能发生泄漏,发热、爆炸,请注意以下预防措施:

- When using a new battery for the first time or after long term storage, please use the battery charger specifically for that purpose fully charge the battery before use.
在使用新电池前, 或者长期存放后第一次使用电池, 在使用前请使用专用充电器将电池充满电。
- Do not disassemble or open, crush, bend or deform, puncture, or shred;
请勿拆解或打开、挤压、弯折、变形、刺穿、敲碎;
- Do not modify or remanufacture, attempt to insert foreign objects into the battery, immerse or expose to water or other liquids such as water, seawater, drinks such as soft drinks, juices, coffee or others, or expose to fire, explosion, or other hazard.
请勿修改或改装, 不要试图将外物插入电池, 不要浸入或暴露在水或其它液体中如淡水、海水、饮料(果汁、咖啡等), 远离火源、爆炸物和其他危险;
- Do not short circuit a battery or allow metallic or conductive objects to contact the battery terminals.
请勿使电池短路, 也不要让金属或其它导体接触电池接电端子;
- When use the battery , must to ensure the charge and discharge voltage of the battery is between 2.50V to 4.25V.
使用电池时需保证每个电池的充放电上下限电压在 2.50V 至 4.25V 之间。
- Avoid dropping the phone or battery. If the phone or battery is dropped, especially on a hard surface, and the user suspects damage, take it to a service center for inspection.
不要跌落主机或电池, 如果主机或电池不慎跌落(尤其在硬表面上), 用户怀疑电池损坏, 则应找服务中心检查;
- The battery replacement shall be done only by either cells supplier or device supplier and never be done by the user.
更换电芯应由电芯供应商或设备供应商完成, 用户不得自行更换。
- Replace the battery only with another battery that has been qualified with the system per standard. Use of an unqualified battery may present a risk of fire, explosion, leakage, or other hazard.
更换电池时只能使用通过标准认证的电池, 使用未经认证的电池可能存在起火、爆炸、或其它危险;

- Don't keep a battery at rest for a long time (over 6 months). Safety accident may happen when recharging battery which has a rest for a long time.
避免电池长时间放置不用（超过 6 个月），长期放置不用的电池重新充电时可能会发生安全问题。
- In the event of a battery leak, do not allow the liquid to come in contact with the skin or eyes. If contact has been made, wash the affected area with large amounts of water and seek medical advice.
如果电池发生漏液，不要让电池接触皮肤和眼睛，如果接触不幸发生，则用大量的水冲洗接触部位或寻求医生帮助；
- Battery usage by children should be supervised. Seek medical advice immediately if a battery has been swallowed
儿童使用电池应受到监督；如果电池被吞食了，立即就医；
- Never disassemble cells. The disassembling may generate internal short circuit in the cell, which may cause firing or other problems.
在任何情况下不得拆卸电芯。拆卸电芯可能会导致内部短路，进而引起着火及其它问题。
- Never incinerate nor dispose the cells in fire. These may cause firing of the cells, which is very dangerous and is prohibited.
在任何情况下，不得燃烧电芯或将电芯投入火中，否则会引起电芯燃烧，这是非常危险的，应绝对禁止。
- Do not remove the outer sleeve from a battery pack nor cut into its housing.
不要把电池（电池组）的外壳去除。
- Do not mix our batteries with other battery brands or batteries of a different chemistry such as alkaline and zinc carbon.
不要将我公司司电池与其他品牌的电池或者不同种类的电池，比如碱性锌电池混用。
- Do not mix new batteries in use with semi-used batteries, over-discharge may occur.
不要将新旧电池混用，可能会导致过放电。
- Promptly dispose of used batteries in accordance with local regulations.
按当地法规迅速处理报废电池；

8.1 ship 运输

The cells might be damaged during shipping by shock. If any abnormal features of the cells are found such as deformation of the cell package, smelling of an electrolyte, an electrolyte leakage and others, the cells shall never be used any more. The Cells with a smell of the electrolyte or a leakage shall be placed away from fire to avoid firing.

电芯在运输过程中可能因撞击等原因而损坏，若发现电芯有任何异常特征，如外壳破损，闻到电解液气味，电解液泄漏等，该电芯不要使用。有电解液泄漏或闻到异常味道的电池应远离火源以避免着火。

8.2 Storage 贮存

The cell shall be stored at the environmental condition of $-20^{\circ}\text{C}\sim 45^{\circ}\text{C}$ and $65\%\pm 20\%$ RH. The voltage for long time storage shall be 3.5V~3.7V range. If the cell has to be storied for a long time (Over 3 months), the environmental condition should be: Temperature: $-20^{\circ}\text{C}\sim 25^{\circ}\text{C}$ Humidity: $65\%\pm 20\%$ RH; please activate the battery once every 3 months according to the following method: Charge with current 0.5C until the voltage achieve to 3.70V.

电芯储存温度必须在 $-20^{\circ}\text{C}\sim 45^{\circ}\text{C}$ ，相对湿度 $65\%\pm 20\%$ 的环境条件下。长期存储电池（超过3个月）须置于温度为 $-20^{\circ}\text{C}\sim 25^{\circ}\text{C}$ 、湿度为 $65\%\pm 20\%$ RH 的环境中。长期贮存电压为 3.5V~3.7V。保质期内每隔3个月对电池用 0.5C 电流进行补充电，至电压达到 3.70V。

9.0 Revision Page 修订记录

Version 版本	Date 日期	Changes 变化	Author 作者
A001	20180529	首版	吴支红
A002	20230721	更改公司 Logo	陈佳

长虹三杰新能源有限公司
Jiangsu SunPower CO., Ltd.
地址: 江苏省泰兴市黄桥工业园区兴园路
Add: XingYuan Rd, HuangQiao industries Zone, TaiXing ,China
电话 Tel: +86 523 87223168
传真 Fax: +86 523 87223168
网址 Website: www.jssanjie.com